

Product Features

- Compliant with FC-PI-4 800-SM-LC-L
- Digital Diagnostic Monitoring available
- SFP+ MSA package with duplex LC connector
- Uncooled 1310nm DFB Laser
- Up to 8.5Gb/s bi-directional data links
- Single +3.3V DC power supply
- Class 1 laser safety certified
- Hot-pluggable SFP footprint
- Commercial operating temperature:
 - (Commercial) 0°C to +70°C
 - (Industrial) -40°C to +85°C
- Up to 10km on 9/125µm SMF
- RoHS Compliant



Applications

- 8.5G Fiber channel

Descriptions

LX4502C(I)DL SFP+ transceivers, according to Enhanced Small Form Factor Pluggable “SFP+” Multi-Sourcing Agreement (MSA) SFF-8431 and SFF-8472, revision 10.4, are designed for use in 8x Fibre Channel application of links up to 10km over single mode fiber.

LX4502IC(I)DL offer commercial and industrial operating temperature options.

Ordering Information

Table 1. Ordering Information

Part Number	Transmitter	Output Power	Receiver	Sensitivity	Reach	Temp	DDM	RoHS
LX4502CDL	1310nm DFB	-8.2 ~ +0.5dBm	PIN	< -14.4dBm	10km	0~ 70°C	Available	Compliant
LX4502IDL	1310nm DFB	-8.2 ~ +0.5dBm	PIN	< -14.4dBm	10km	-40 ~ 85°C	Available	Compliant

Pin Description

Table 2. Pin Description

Pin	Name	Function/Description	Notes
1	VeeT	Transmitter Ground	1
2	TX_Fault	Transmitter Fault (LVTTTL-O) - High indicates a fault condition	2
3	TX_Disable	Transmitter Disable (LVTTTL-I) – High or open disables the transmitter	3
4	SDA	Two wire serial interface Data Line (LVCMOS-I/O) (MOD-DEF2)	4

5	SCL	Two wire serial interface Clock Line (LVCMOS-I/O) (MOD-DEF1)	4
6	MOD_ABS	Module Absent (Output), connected to VeeT or VeeR in the module	5
7	RS0	Rate Select 0 – Not used, Presents high input impedance	-
8	RX_LOS	Receiver Loss of Signal (LVTTTL-O)	2
9	RS1	Rate Select 1 – Not used, Presents high input impedance	-
10	VeeR	Receiver Ground	1
11	VeeR	Receiver Ground	1
12	RD-	Inverse Received Data out (CML-O)	-
13	RD+	Received Data out (CML-O)	-
14	VeeR	Receiver Ground	-
15	VccR	Receiver Power - +3.3V	-
16	VccT	Transmitter Power - +3.3 V	-
17	VeeT	Transmitter Ground	1
18	TD+	Transmitter Data In (CML-I)	-
19	TD-	Inverse Transmitter Data In (CML-I)	-
20	VeeT	Transmitter Ground	1

Notes:

1. The module signal grounds are isolated from the module case.
2. This is an open collector/drain output that on the host board requires a 4.7KΩ to 10KΩ pull-up resistor to VccHost.
3. This input is internally biased high with a 4.7KΩ to 10KΩ pull-up resistor to VccT.
4. Two-Wire Serial interface clock and data lines require an external pull-up resistor dependent on the capacitance load.
5. This is a ground return that on the host board requires a 4.7KΩ to 10KΩ pull-up resistor to VccHost.

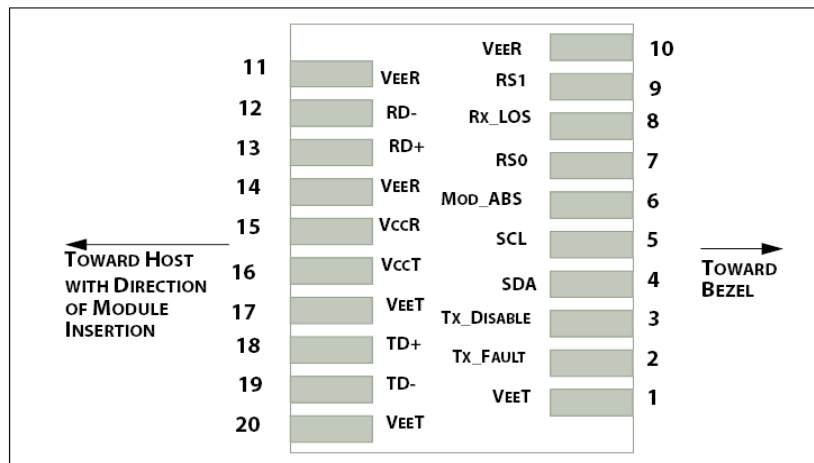

Figure 1. Host PCB SFP+ pad assignment top view

Absolute Maximum Ratings

Stresses in excess of the absolute maximum ratings can cause permanent damage to the device. These are absolute stress ratings only. Functional operation of the device is not implied at these or any other conditions in excess of those given in the operational sections of the data sheet. Exposure to absolute maximum ratings for extended periods can adversely affect device reliability.

Table 3. Absolute Maximum Ratings

Parameter	Symbol	Minimum	Maximum	Unit
Storage Temperature	T _s	-40	85	°C
Relative Humidity	RH	5	95	%
Supply Voltage	V _{CC}	-0.5	4.0	V

Recommended Operating Conditions

Table 4. Recommended Operating Conditions

Parameter	Symbol	Min	Typ	Max	Unit	
Operating Temperature	LX4502CDL	T _C	0	25	70	°C
	LX4502IDL	T _C	-40	25	85	°C
Supply Voltage	V _{CC}	3.135	3.3	3.465	V	
Data Rate	-	-	8.5	-	Gb/s	

Transceiver Electrical Characteristics

Table 5. Transceiver Electrical Characteristics

Parameter	Symbol	Minimum	Typical	Maximum	Unit	Notes	
Module Supply Current	I _{CC}	-	-	290	mA	-	
Power Dissipation	P _D	-	-	1000	mW	-	
Transmitter							
Input Differential Impedance	Z _{IN}	-	100	-	Ω	-	
Differential Data Input Swing	V _{IN, P-P}	180	-	700	mV _{P-P}	-	
TX_FAULT	Transmitter Fault	V _{OH}	2.0	-	V _{CCHOST}	V	-
	Normal Operation	V _{OL}	0	-	0.8	V	-
TX_DISABLE	Transmitter Disable	V _{IH}	2.0	-	V _{CCHOST}	V	-
	Transmitter Enable	V _{IL}	0	-	0.8	V	-
Receiver							
Output Differential Impedance	Z _O	-	100	-	Ω	-	
Differential Data Output Swing	V _{OUT, P-P}	300	-	850	mV _{P-P}	1	
Data Output Rise Time, Fall Time	t _r , t _f	28	-	-	ps	2	
RX_LOS	Loss of signal (LOS)	V _{OH}	2.0	-	V _{CCHOST}	V	3
	Normal Operation	V _{OL}	0	-	0.8	V	3

Notes:

- Internally AC coupled, but requires a external 100Ω differential load termination.
- 20 – 80 %.
- LOS is an open collector output. Should be pulled up with 4.7kΩ on the host board.

Transmitter Optical Characteristics

Table 6. Transmitter Optical Characteristics

Parameter	Symbol	Minimum	Typical	Maximum	Unit	Notes
Launch Optical Power	P _o	-8.2	-	+0.5	dBm	1
Center Wavelength Range	λ _c	1260	1310	1355	nm	-
Extinction Ratio	EX	3.5	-	-	dB	2
Optical Modulation Amplitude	OMA	-5.2	-	-	dBm	
Spectral Width (-20dB)	Δλ	-	-	1	nm	-
Side Mode Suppression Ratio	SMSR	30	-	-	dB	-
Transmitter and Dispersion Penalty	TDP	-	-	3.2	dB	-
Optical Return Loss Tolerance	ORLT	-	-	12	dB	-
P _{out} @TX-Disable Asserted	P _{off}	-	-	-30	dBm	1

Notes:

1. The optical power is launched into 9/125μm SMF.
2. Measured with a PRBS 2³¹-1 test pattern @8.5Gbps.

Receiver Optical Characteristics

Table 7. Receiver Optical Characteristics

Parameter	Symbol	Minimum	Typical	Maximum	Unit	Notes
Center Wavelength	λ _c	1260	1310	1355	nm	-
Receiver Sensitivity (P _{avg})	S	-	-	-14.4	dBm	1
Receiver Sensitivity (OMA)	S _{OMA}	-	-	-12.6	dBm	1
Receiver Overload (P _{avg})	P _{OL}	0.5	-	-	dBm	1
Stressed Sensitivity (OMA)	-	-	-	-10.3	dBm	2
Optical Return Loss	ORL	12	-	-	dB	-
LOS De-Assert	LOS _D	-	-	-17	dBm	-
LOS Assert	LOS _A	-30	-	-	dBm	-
LOS Hysteresis	-	0.5	-	-	dB	-

Notes:

1. Measured with PRBS 2³¹-1 test pattern, 8.5Gb/s, BER<10⁻¹².

Recommended Host Board Power Supply Filter Network

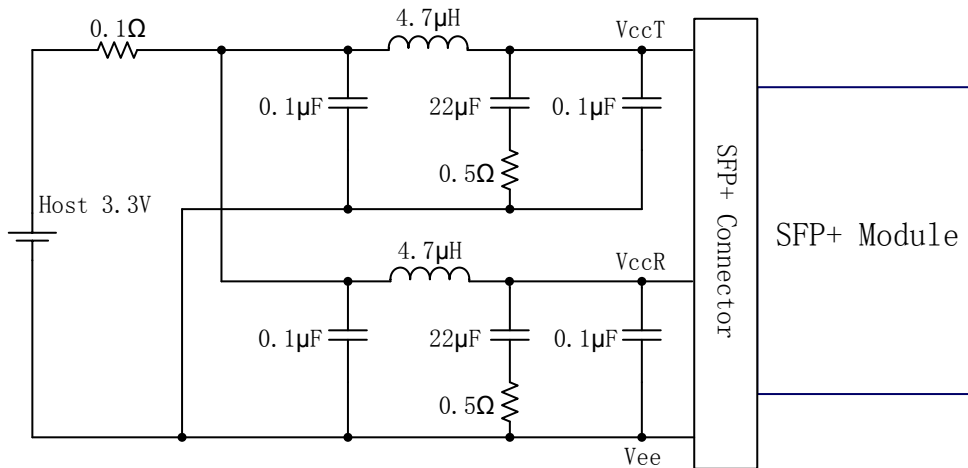

Figure 2. Recommended Host Board Power Supply Filter Network

Recommended Application Interface Block Diagram

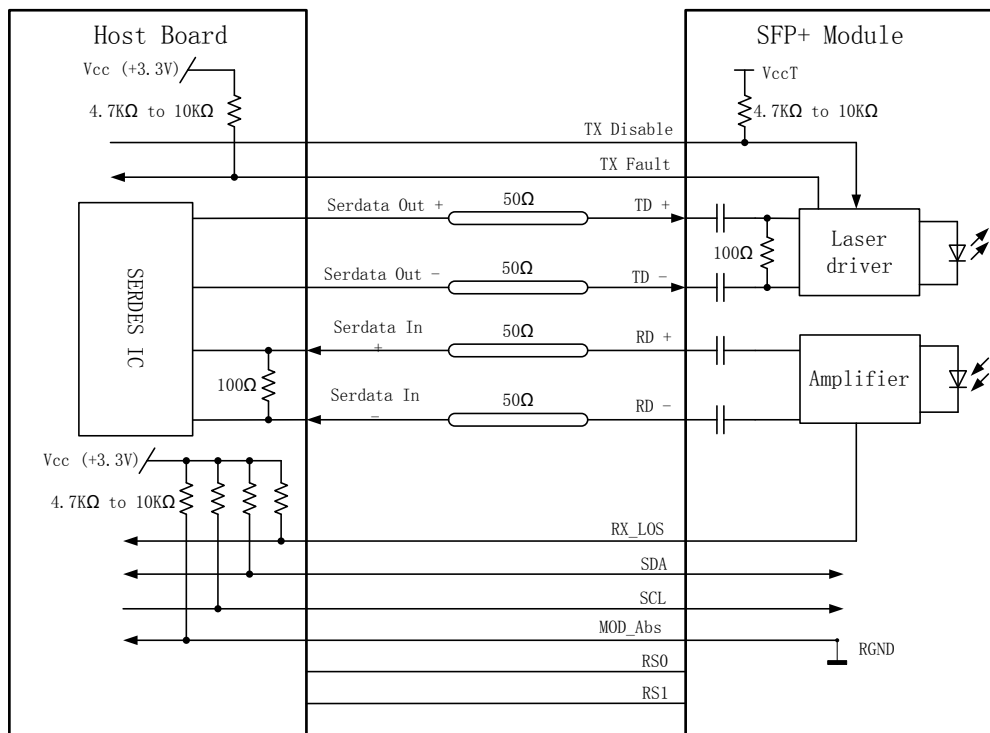

Figure 3. Recommended Application Interface Block Diagram

Mechanical specifications

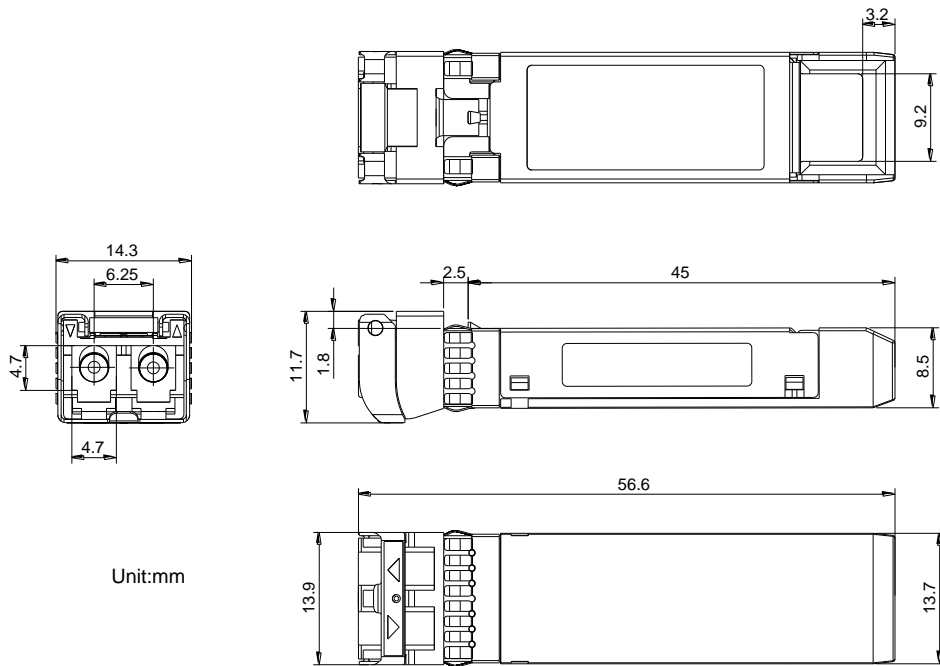
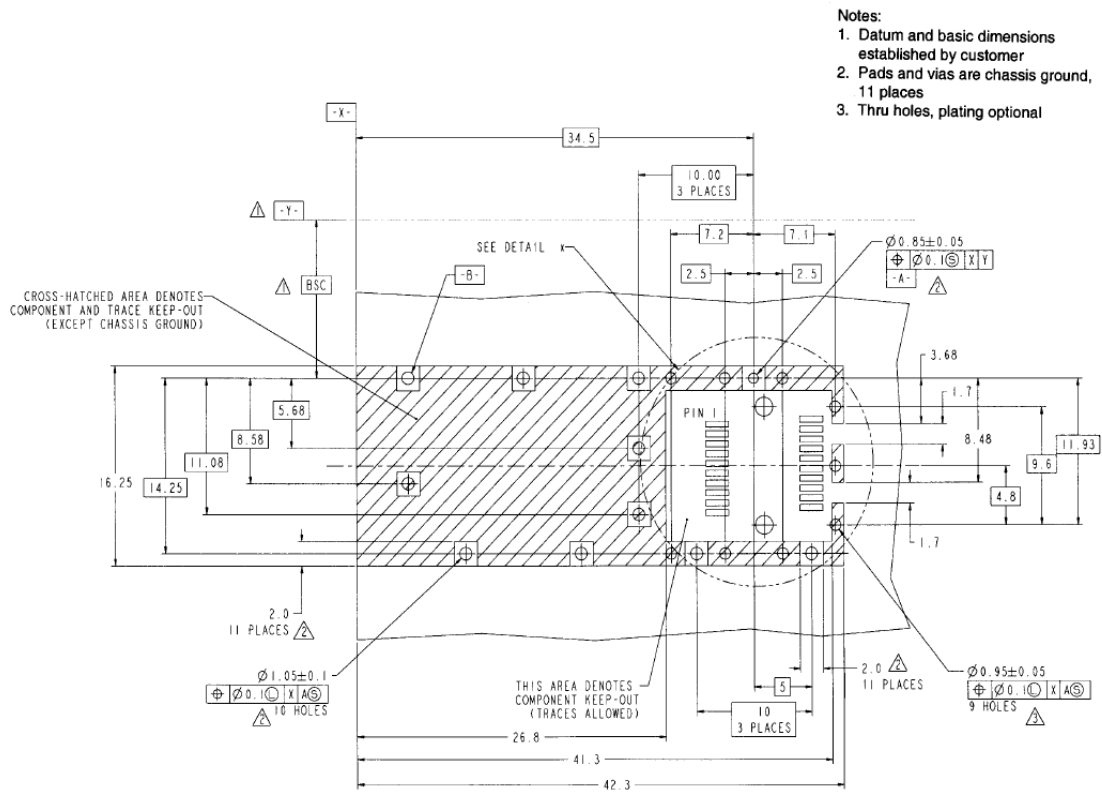

Figure 4. Outline Drawing

PCB layout recommendation



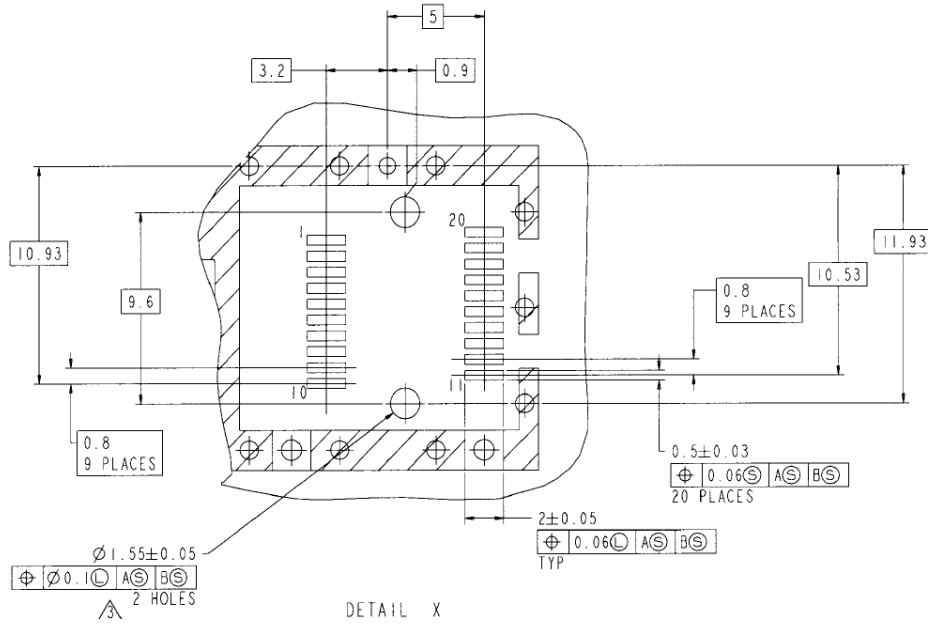

Figure 5. PCB layout recommendation



LX4502xDL
8.5G Single Mode SFP+ Transceiver
8G Fiber channel

For More Information

Linktel Technologies Co., Ltd

sales@linkteltech.com

<http://www.linkteltech.com>

Linktel China

No.20 University Science Park Road, East-lake Hi-tech Development Zone, Wuhan, 430223, China

Tel: +86 27-87929302

Linktel USA

3311 Ingersoll Court, San Jose, CA 95148

Tel: +1(408)833-9142

linktelus@linkteltech.com