

Product Features

- Electrical interface specifications per SFF-8431
- Management interface specifications per SFF-8431 and SFF-8472
- SFP+ MSA package with Single LC receptacle
- 1270nm DFB Laser, PIN photo-detector
- Up to 11.3G bi-directional data links
- Single +3.3V power supply
- Class 1 laser safety certified
- Operating temperature Options
 - (Commercial) 0°C to +70°C
 - (Industrial) -40°C to +85°C
- Up to 20km on 9/125 μm SMF
- RoHS6 Compliant



Applications

- 10GBASE-BX Ethernet
- 10GBASE-LR at 10.3125Gbps
- 10GBASE-LW at 9.953Gbps
- CPRI and OBSAI
- 2x/4x/8x Fiber Channel

Descriptions

LX4411C(I)DR are designed for Single Fiber Bidirectional serial optical data communications up to 11.3 Gb/s. The electrical interface is compliant with SFI specifications of SFF-8431. The transceiver consists of 10Gbit/s 1270nm DFB optical transmitter and PIN receiver, and transmission distance up to 20Km on single mode fiber. LX4411C(I)DR offer commercial and industrial operating temperature options.

Ordering Information

Table 1. Ordering Information

Part Number	Transmitter	Output Power	Receiver	Sensitivity	Reach	Temp	DDM	RoHS
LX4411CDR	1270nm DFB	-4 ~ +2dBm	1330nm PIN	< -14.4dBm	20km	0 ~ 70 °C	Available	Compliant
LX4411IDR	1270nm DFB	-4 ~ +2dBm	1330nm PIN	< -14.4dBm	20km	-40 ~ 85 °C	Available	Compliant

Pin Description

Table 2. Pin Description

Pin	Name	Function/Description	Notes
1	VeeT	Transmitter Ground	1
2	TX_Fault	Transmitter Fault (LVTTTL-O) - High indicates a fault condition	2
3	TX_Disable	Transmitter Disable (LVTTTL-I) – High or open disables the transmitter	3

4	SDA	Two wire serial interface Data Line (LVCMOS-I/O) (MOD-DEF2)	4
5	SCL	Two wire serial interface Clock Line (LVCMOS-I/O) (MOD-DEF1)	4
6	MOD_ABS	Module Absent (Output), connected to VeeT or VeeR in the module	5
7	RS0	Internal 33KΩ pull-down to ground	-
8	RX_LOS	Receiver Loss of Signal (LVTTTL-O)	2
9	RS1	Internal 33KΩ pull-down to ground	-
10	VeeR	Receiver Ground	1
11	VeeR	Receiver Ground	1
12	RD-	Inverse Received Data out (CML-O)	-
13	RD+	Received Data out (CML-O)	-
14	VeeR	Receiver Ground	-
15	VccR	Receiver Power - +3.3V	-
16	VccT	Transmitter Power - +3.3 V	-
17	VeeT	Transmitter Ground	1
18	TD+	Transmitter Data In (CML-I)	-
19	TD-	Inverse Transmitter Data In (CML-I)	-
20	VeeT	Transmitter Ground	1

Notes:

1. The module signal grounds are isolated from the module case.
2. This is an open collector/drain output that on the host board requires a 4.7KΩ to 10KΩ pull-up resistor to VccHost.
3. This input is internally biased high with a 4.7KΩ to 10KΩ pull-up resistor to VccT.
4. Two-Wire Serial interface clock and data lines require an external pull-up resistor dependent on the capacitance load.
5. This is a ground return that on the host board requires a 4.7KΩ to 10KΩ pull-up resistor to VccHost.

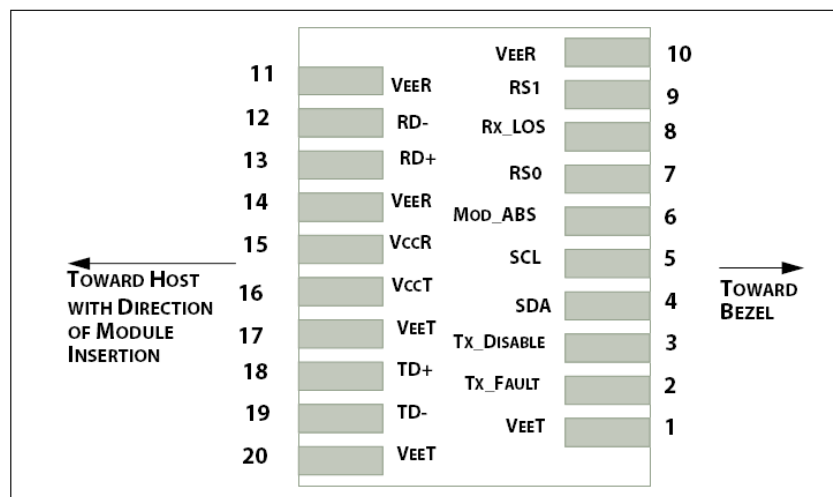

Figure 1. Host PCB SFP+ pad assignment top view

Absolute Maximum Ratings

Stresses in excess of the absolute maximum ratings can cause permanent damage to the device. These are absolute stress ratings only. Functional operation of the device is not implied at these or any other conditions in excess of those given in the operational sections of the data sheet. Exposure to absolute maximum ratings for extended periods can adversely affect device reliability.

Table 3. Absolute Maximum Ratings

Parameter	Symbol	Minimum	Maximum	Unit
Storage Temperature	T _s	-40	85	°C
Relative Humidity	RH	5	95	%
Supply Voltage	V _{CC}	-0.3	4.0	V

Recommended Operating Conditions

Table 4. Recommended Operating Conditions

Parameter	Symbol	Min	Typ	Max	Unit	
Operating Case Temperature	LX4411CDR	T _c	0	25	70	°C
	LX4411IDR	T _c	-40	25	85	°C
Supply Voltage	V _{CC}	3.135	3.3	3.465	V	
Data Rate	-	0.1	9.95 10.3	11.3	Gb/s	

Transceiver Electrical Characteristics

Table 5. Transceiver Electrical Characteristics

Parameter	Symbol	Minimum	Typical	Maximum	Unit	Notes	
Module Supply Current	I _{CC}	-	-	350	mA	-	
Power Dissipation	P _D	-	-	1200	mW	-	
Transmitter							
Input Differential Impedance	Z _{IN}	-	100	-	Ω	-	
Differential Data Input Swing	V _{IN, P-P}	180	-	700	mV _{P-P}	-	
TX_FAULT	Transmitter Fault	V _{OH}	2.0	-	V _{CCHOST}	V	-
	Normal Operation	V _{OL}	0	-	0.8	V	-
TX_DISABLE	Transmitter Disable	V _{IH}	2.0	-	V _{CCHOST}	V	-
	Transmitter Enable	V _{IL}	0	-	0.8	V	-
Receiver							
Output Differential Impedance	Z _O	-	100	-	Ω	-	
Differential Data Output Swing	V _{OUT, P-P}	400	-	850	mV _{P-P}	1	

Data Output Rise Time, Fall Time	t_r, t_f	-	60	ps	2		
RX_LOS	Loss of signal (LOS)	V_{OH}	2.0	-	V_{CCHOST}	V	3
	Normal Operation	V_{OL}	0	-	0.8	V	3

Notes:

1. Internally AC coupled, but requires a external 100Ω differential load termination.
2. 20–80%.
3. LOS is an open collector output. Should be pulled up with 4.7kΩ on the host board.

Transmitter Optical Characteristics

Table 6. Transmitter Optical Characteristics

Parameter	Symbol	Minimum	Typical	Maximum	Unit	Notes
Launch Optical Power	P_o	-4	-	+2	dBm	1
Center Wavelength Range	λ_c	1260	1270	1280	nm	-
Extinction Ratio	EX	3.5	-	-	dB	2
Optical Modulation Amplitude	OMA	-5.2	-	-	dBm	
Spectral Width (-20dB)	$\Delta\lambda$	-	-	1	nm	-
Side Mode Suppression Ratio	SMSR	30	-	-	dB	-
Relative Intensity Noise	RIN			-128	dB/Hz	
Pout @TX-Disable Asserted	P_{off}	-	-	-35	dBm	1

Notes:

1. The optical power is launched into 9/125 μm SMF.
2. Measured with a PRBS 2³¹-1 test pattern @10.3125Gbps.

Receiver Optical Characteristics

Table 7. Receiver Optical Characteristics

Parameter	Symbol	Minimum	Typical	Maximum	Unit	Notes
Center Wavelength	λ_c	1320	1330	1340	nm	-
Receiver Sensitivity (P_{avg})	S	-	-	-14.4	dBm	1
Receiver Overload (P_{avg})	P_{OL}	0.5	-	-	dBm	1
Optical Return Loss	ORL	12	-	-	dB	-
LOS De-Assert	LOS_D	-	-	-17	dBm	-
LOS Assert	LOS_A	-30	-	-	dBm	-
LOS Hysteresis	-	0.5	-	-	dB	-

Notes:

1. Measured with PRBS 2³¹-1 test pattern, 10.3125Gb/s, BER<10⁻¹².

Digital Diagnostic Memory Map

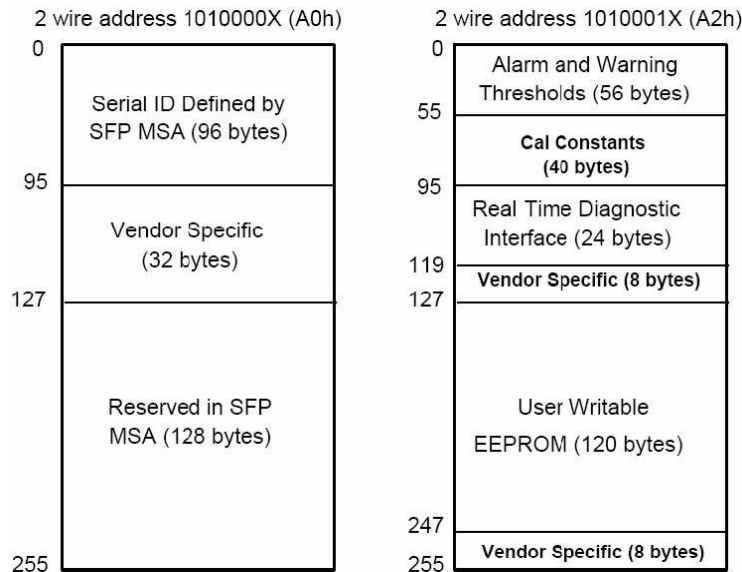

Figure 2. Digital Diagnostic Memory Map Specific Data Field Descriptions

EEPROM Serial ID Memory Contents

The SFP MSA defines a 256-byte memory map in EEPROM describing the transceiver’s capabilities, standard interfaces, manufacturer, and other information, which is accessible over a 2-wire serial interface at the 8-bit address 1010000X (A0h), and the clock frequency up to 100KHz. The memory contents are shown in Table 8.

Table 8. Serial ID Memory Contents

Data Address	Name of Field	Contents(Hex)	Description
0	Identifier	03	SFP
1	Ext. Identifier	04	SFP function is defined by serial ID
2	Connector	07	LC
3-10	Transceiver	20 00 00 00 00 10 01 80	10G Base-LR
11	Encoding	06	64B/66B
12	BR, Nominal	67	10.3Gb/s
13	Reserved	00	-
14	Length (9µm) km	14	20km
15	Length (9µm) 100m	C8	20000m
16	Length (50µm) 10m	00	-
17	Length(62.5µm)10m	00	-
18	Length (Copper)	00	-
19	Reserved	00	-

20-35	Vendor name	4C 49 4E 4B 54 45 4C 20 20 20 20 20 20 20 20 20	LINKTEL (ASCII)
36	Reserved	00	
37-39	Vendor OUI	00 00 00	
40-55	Vendor PN	4C 58 34 34 31 31 xx 44 52 20 20 20 20 20 20 20	LX4411xDR
56-59	Vendor rev	31 2E 30 20	Rev 1.0 (ASCII)
60-62	Wavelength	04 F6 00	1270nm
63	CC BASE	xx	Check sum of bytes 0 - 62
64-65	Options	00 1A	LOS, TX_FAULT and TX_DISABLE
66	BR, max	00	
67	BR, min	00	
68-83	Vendor SN	33 31 34 30 34 30 37 30 31 33 20 20 20 20 20 20	Serial Number of transceiver (ASCII). For example "3140407013".
84-91	Vendor date code	xx xx xx xx xx xx 20 20	Year (2 bytes), Month (2 bytes), Day (2 bytes)
92	Diagnostic type	68	Diagnostics (Internally Cal)
93	Enhanced option	F0	Diagnostics(Optional Alarm/warning flags, Soft TX_DIS, Soft TX_FAULT and Soft TX_LOS monitoring)
94	SFF-8472	03	Diagnostics(SFF-8472 Rev 10.2)
95	CC_EXT	xx	Check sum for bytes 64-94
96-255		00	

Note: The “xx” byte should be filled in according to practical case. For more information, please refer to the related document of SFF-8472 Rev 10.2.

Diagnostic Monitor Specifications

The digital diagnostic monitoring interface also defines another 256-byte memory map in EEPROM, which makes use of the 8 bit address 1010001X (A2h). Please see Figure 2. For detail EEPROM information, please refer to the related document of SFF-8472 Rev 10.2. The monitoring specification of this product is described in Table 9.

Table 9. Diagnostic Monitor Specifications

	Parameter	Range	Accuracy	Calibration
Temperature	LX4411CDR	-10 to +80 °C	±3 °C	Internal
	LX4411IDR	-40 to +90 °C	±3 °C	Internal
Voltage		3.0 to 3.6V	±3%	Internal
Bias Current		0 to 100mA	±10%	Internal
TX Power		-5 to +3dBm	±2dB	Internal
RX Power		-15 to +1dBm	±2dB	Internal

Recommended Host Board Power Supply Filter Network

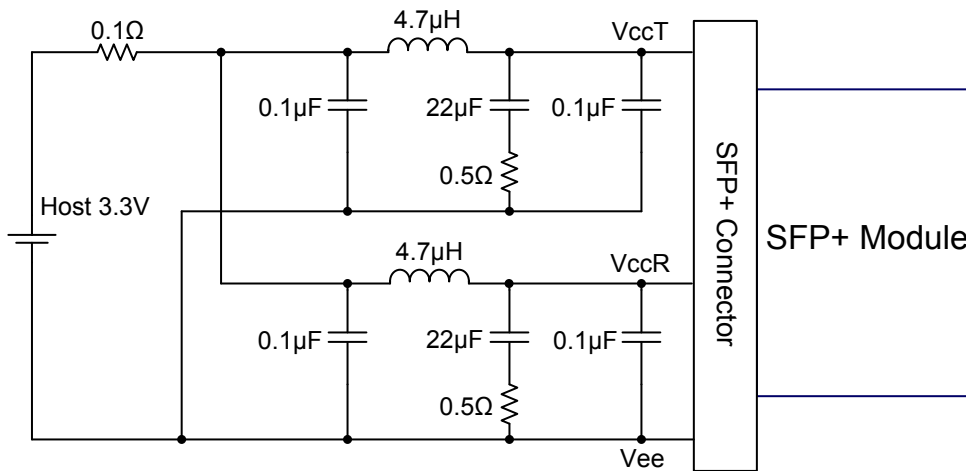

Figure 2. Recommended Host Board Power Supply Filter Network

Recommended Application Interface Block Diagram

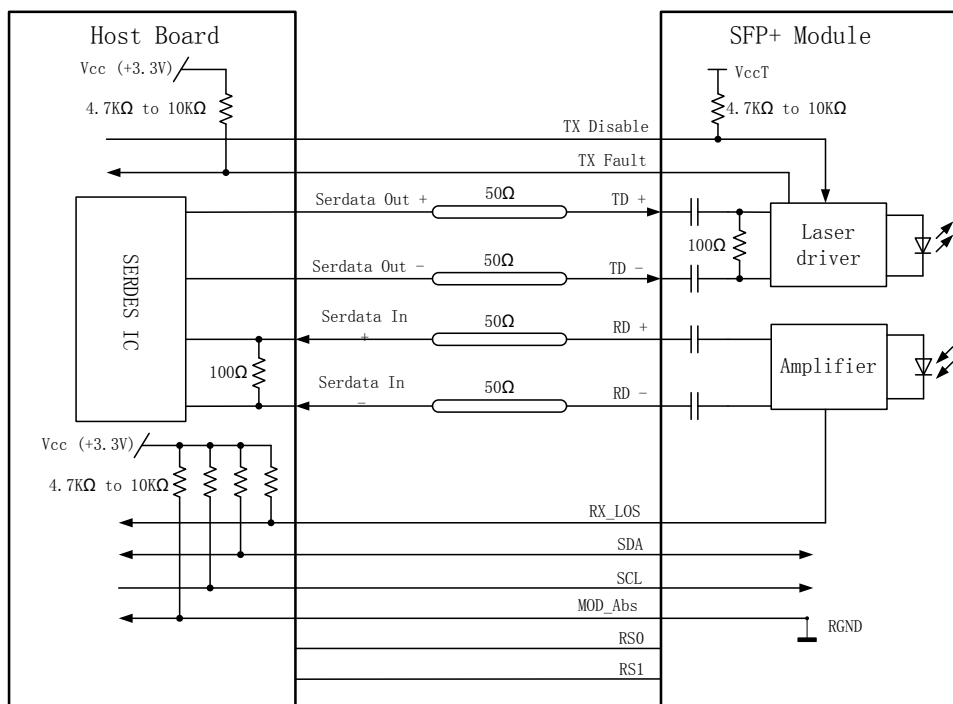

Figure 4. Recommended Application Interface Block Diagram

Mechanical specifications

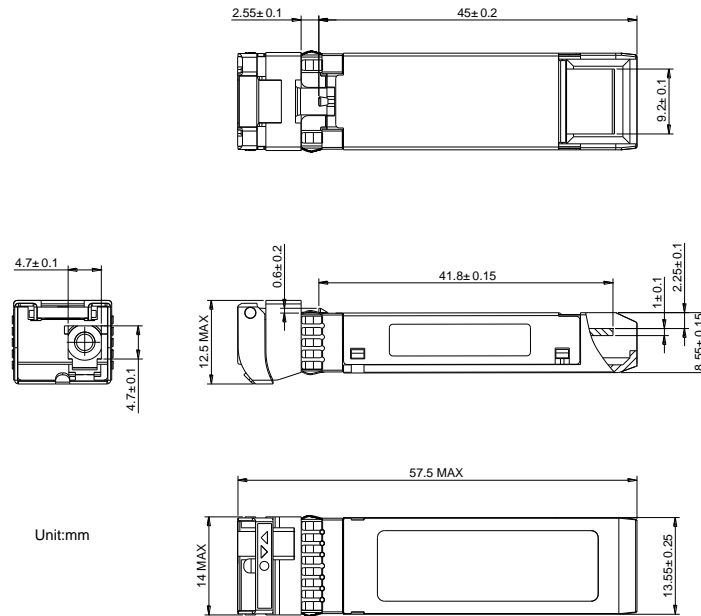
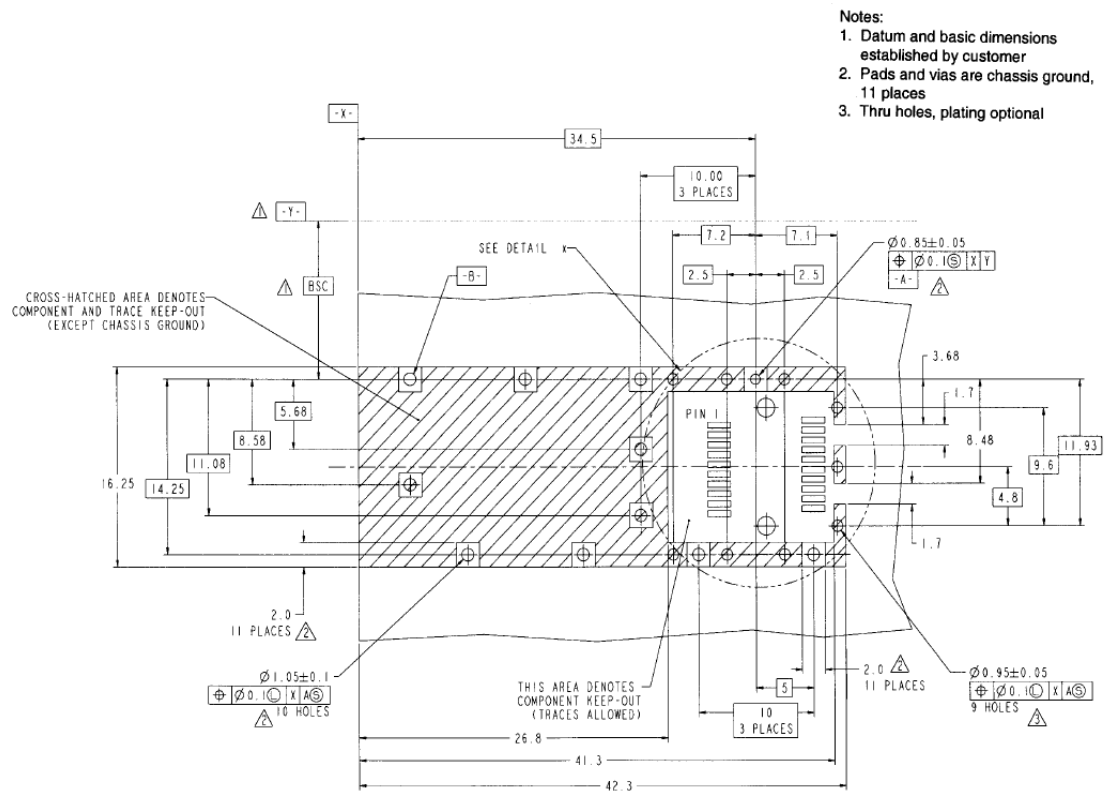

Figure 5. Outline Drawing

PCB layout recommendation



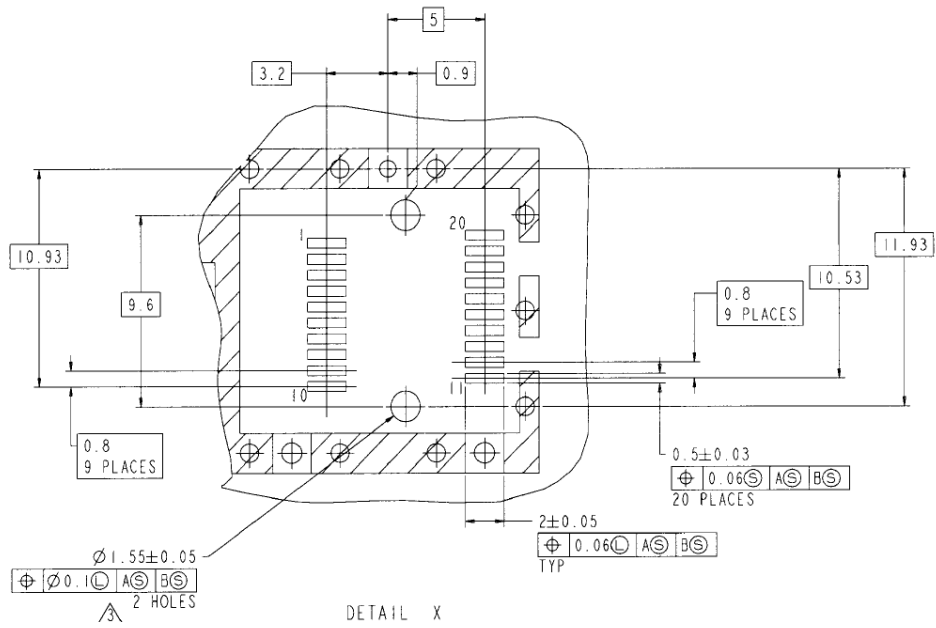

Figure 6. PCB layout recommendation

For More Information

Linktel Technologies Co., Ltd

info@linkteltech.com

www.linkteltech.com

Linktel China

No. 20, University Science Park Road,

East Lake Hi-tech Development Zone, Wuhan, 430223, China

Tel: +86 27-87929302

Linktel USA

1601 McCarthy Blvd #9, Milpitas, CA 95035, USA

linktelus@linkteltech.com

Tel: +1 408 807 0482