

## Product Features

- Compliant with IEEE Std 802.3-2005  
10Gb Ethernet 10GBase-BX
- XFP MSA Rev. 4.5 compliant
- Full digital diagnostic management interface
- XFP MSA package with  
Single LC receptacle optical
- Uncooled 1270nm DFB Laser
- Up to 11.3Gb/s bi-directional data links
- Class 1 laser safety certified
- Commercial operating temperature:
  - (Commercial) 0°C to +70°C
  - (Industrial) -40°C to +85°C
- Up to 60km on 9/125µm SMF
- RoHS6 Compliant



## Applications

- 10G Ethernet 10GBASE-BX
- 10GBASE-LR at 10.3125Gbps
- 10GBASE-LW at 9.953Gbps
- 2x/4x/8x Fiber Channel
- Optical Storage Network

## Descriptions

LX3431C(I)DR XFP transceivers, according to 10 Gigabit Small Form Factor Pluggable Module Multi-Sourcing Agreement (XFP-MSA) INF-8077i Revision 4.5, are designed for bidirectional serial optical data communications up to 60km. They are compatible with IEEE Std 802.3-2005 10G Ethernet 10GBase-BX. LX3431C (I)DR offer commercial and industrial operating temperature options.

## Ordering Information

**Table 1. Ordering Information**

Part Number	Transmitter	Output Power	Receiver	Sensitivity	Reach	Temp	DDM	RoHS
LX3431CDR	1270nm DFB	0 ~ +5dBm	1330nm APD	< -21dBm	60km	0 ~ 70°C	Available	Compliant
LX3431IDR	1270nm DFB	0 ~ +5dBm	1330nm APD	< -21dBm	60km	-40 ~ 85°C	Available	Compliant

## Electrical Pin Description

**Table 2. Electrical Pin Description**

	Logic	Symbol	Name/Description	Note
1	-	GND	Module Ground	1
2	-	V <sub>EE5</sub>	Optional -5.2V Power Supply - <b>Not Required</b>	-

3	LVTTL-I	Mod_DeSel	Module De-select; When held low allows module to respond to 2-wire serial interface	-
4	LVTTL-O	Interrupt	Interrupt; Indicates presence of an important condition which can be read over the 2-wire serial interface	2
5	LVTTL-I	TX_DIS	Transmitter Disable; Turns off transmitter laser output	-
6	-	VCC5	+5V Power Supply- <b>Not Required</b>	-
7	-	GND	Module Ground	1
8	-	VCC3	+3.3V Power Supply	-
9	-	VCC3	+3.3V Power Supply	-
10	LVTTL-I/O	SCL	2-Wire Serial Interface Clock	2
11	LVTTL-I/O	SDA	2-Wire Serial Interface Data Line	2
12	LVTTL-O	Mod_Abs	Indicates Module is not present. Grounded in the Module	2
13	LVTTL-O	Mod_NR	Module Not Ready; Indicating Module Operational Fault	2
14	LVTTL-O	RX_LOS	Receiver Loss Of Signal Indicator	2
15	-	GND	Module Ground	1
16	-	GND	Module Ground	1
17	CML-O	RD-	Receiver Inverted Data Output	-
18	CML-O	RD+	Receiver Non-Inverted Data Output	-
19	-	GND	Module Ground	1
20	-	VCC2	+1.8V Power Supply - <b>Not Required</b>	-
21	LVTTL-I	P_Down/RST	Power down; When high, requires the module to limit power consumption to 1.5W or below. 2-Wire serial interface must be functional in the low power mode. Reset; The falling edge initiates a complete reset of the module including the 2-wire serial interface, equivalent to a power cycle.	-
22	-	VCC2	+1.8V Power Supply - <b>Not Required</b>	-
23	-	GND	Module Ground	1
24	PECL-I	RefCLK+	Reference Clock Non-Inverted Input, AC coupled on the host board - <b>Not Required</b>	3
25	PECL-I	RefCLK-	Reference Clock Inverted Input, AC coupled on the host board - <b>Not Required</b>	3
26	-	GND	Module Ground	1
27	-	GND	Module Ground	1
28	CML-I	TD-	Transmitter Inverted Data Input	-
29	CML-I	TD+	Transmitter Non-Inverted Data Input	-
30	-	GND	Module Ground	1

**Notes:**

1. Module ground pins GND are isolated from the module case.
2. Shall be pulled up with 4.7K $\Omega$  to 10K $\Omega$  to a voltage between 3.15V and 3.45V on the host board.
3. Reference Clock is not required. If present, it will be ignored.

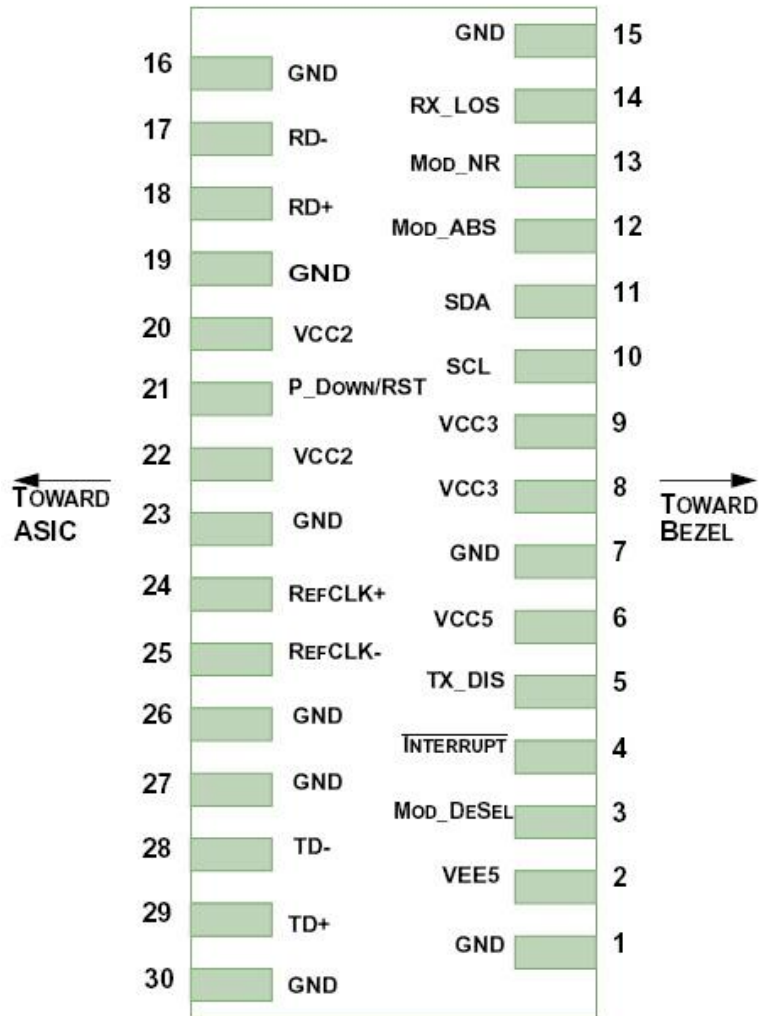

Figure 1. Host PCB XFP Pinout Top View

## Absolute Maximum Ratings

Stresses in excess of the absolute maximum ratings can cause permanent damage to the device. These are absolute stress ratings only. Functional operation of the device is not implied at these or any other conditions in excess of those given in the operational sections of the data sheet. Exposure to absolute maximum ratings for extended periods can adversely affect device reliability.

**Table 3. Absolute Maximum Ratings**

Parameter	Symbol	Minimum	Maximum	Unit
Storage Temperature	T <sub>s</sub>	-40	85	°C
Relative Humidity	RH	5	95	%
Supply Voltage	V <sub>CC3</sub>	-0.5	4.0	V

## Recommended Operating Conditions

**Table 4. Recommended Operating Conditions**

Parameter	Symbol	Min	Typ	Max	Unit
Operating Case Temperature (Commercial )	T <sub>C</sub>	0	-	70	°C
Operating Case Temperature (Industrial )	T <sub>C</sub>	-40	-	85	°C
Supply Voltage	V <sub>CC3</sub>	3.135	3.3	3.465	V
Data Rate	-	9.95	-	11.3	Gb/s

## Transceiver Electrical Characteristics

**Table 5. Transceiver Electrical Characteristics**

Parameter	Symbol	Minimum	Typical	Maximum	Unit	Notes
Supply Current	I <sub>CC3</sub>	-	-	600	mA	-
Power Dissipation	P <sub>D</sub>	-	1500	2000	mW	-
<b>Transmitter</b>						
Input Differential Impedance	Z <sub>IN</sub>	-	100	-	Ω	-
Differential Data Input Swing	V <sub>IN, P-P</sub>	120	-	1000	mV <sub>P-P</sub>	-
Tx_Disable, P_Down/RST	V <sub>IH</sub>	2.0	-	V <sub>CC3</sub> +0.3	V	-
	V <sub>IL</sub>	-0.3	-	0.8	V	-
Transmit Disable Assert Time	-	-	-	10	us	-
<b>Receiver</b>						
Output Differential Impedance	Z <sub>O</sub>	-	100	-	Ω	-
Differential Data Output Swing	V <sub>OUT, P-P</sub>	340	-	850	mV <sub>P-P</sub>	1
Data Output Rise Time, Fall Time	t <sub>r</sub> , t <sub>f</sub>	24	-	-	ps	2
Rx_LOS, Mod_NR, Interrupt	V <sub>OH</sub>	V <sub>CCHOST</sub> -0.5	-	V <sub>CCHOST</sub> +0.3	V	3
	V <sub>OL</sub>	0	-	0.4	V	3

**Notes:**

1. Internally AC coupled, but requires a external 100Ω differential termination.
2. 20–80%.
3. Loss Of Signal is an open collector output. Should be pulled up with a 4.7kΩ-10kΩ resistor on the host board.

## Transmitter Optical Characteristics

**Table 6. Transmitter Optical Characteristics**

Parameter	Symbol	Minimum	Typical	Maximum	Unit	Notes
Launch Average Optical Power	P <sub>o</sub>	0	-	+5	dBm	1
Center Wavelength Range	λ <sub>c</sub>	1260	1270	1280	nm	-
Extinction Ratio	EX	6	-	-	dB	2
Spectral Width (-20dB)	Δλ	-	-	1	nm	-

Side Mode Suppression Ratio	SMSR	30	-	-	dB	-
Transmitter and Dispersion Penalty	TDP	-	-	1	dB	3
Average Optical Power (Laser Off)	P <sub>OFF</sub>	-	-	-30	dBm	1
Eye Diagram	ITU-T G.691 SDH STM-64 I-64.1 compatible					2

**Notes:**

1. The optical power is launched into 9/125μm SMF.
2. Measured with a PRBS 2<sup>31</sup>-1 test pattern @ 9.953Gbps.
3. Measured with 60km G.652 SMF.

## Receiver Optical Characteristics

**Table 7. Receiver Optical Characteristics**

Parameter	Symbol	Minimum	Typical	Maximum	Unit	Notes
Center Wavelength	λ <sub>c</sub>	1320	1330	1340	nm	-
Receiver Sensitivity (P <sub>avg</sub> )	S	-	-	-21	dBm	1
Receiver Overload (P <sub>avg</sub> )	P <sub>OL</sub>	-8	-	-	dBm	1
Optical Return Loss	ORL	14	-	-	dB	-
LOS De-Assert	LOS <sub>D</sub>	-	-	-22	dBm	-
LOS Assert	LOS <sub>A</sub>	-32	-	-	dBm	-
LOS Hysteresis	-	0.5	-	-	dB	-

**Notes:**

1. Measured with worst ER; 1330nm; PRBS 2<sup>31</sup>-1 test pattern, BER<10<sup>-12</sup>.

## EEPROM Serial ID Memory Contents

The XFP SMA defines the operation of the XFP 2-wire serial interface which is used for serial ID, digital diagnostics, and certain control functions. The 2-wire serial interface is mandatory for all XFP modules. Received power monitoring, transmitted power monitoring, bias current monitoring, supply voltage monitoring and temperature monitoring all are implemented. The memory contents are shown in Table 8.

**Table 8. Serial ID Memory Contents**

Data Address	Name of Field	Contents(Hex)	Description
128	Identifier	06	XFP
129	Ext. Identifier	50	2.5W max, No TX Ref Clock Input
130	Connector	07	LC
131-138	Transceiver	44 40 00 00 40 00 00 00	10GBASE-LR/LW,1200-SM-LL-L,I-64.1,10GFiber channel
139	Encoding	F0	64B/66B,SONET Scrambled,NRZ
140	BR-Min	63	9.953Gb/s
141	BR-Max	71	11.3Gb/s

142	Length (SMF)-km	3C	60km
143	Length (E-50µm)	00	-
144	Length (50µm)	00	-
145	Length(62.5µm)	00	-
146	Length (Copper)	00	-
147	Device Tech	40	1270nm DFB, PIN Detector
148-163	Vendor name	4C 49 4E 4B 54 45 4C 20 20 20 20 2020 20 20 20	“LINKTEL”(ASCII)
164	CDR Support	F8	CDR supports 9.953Gbps to 11.1Gbps
165-167	Vendor OUI	00 00 00	
168-183	Vendor PN	4C 58 33 34 33 31 xx 44 52 20 20 20 20 20 20 20	“LX3431xDR ” (ASCII)
184-185	Vendor rev	31 30	Rev 10 ( ASCII)
186-187	Wavelength(1/20nm)	63 38	1270nm
188-189	Wavelength Tolerance	07 D0	+/-20nm
190	Max Case Temp	46	70°C
191	CC_BASE	xx	Check sum of bytes 128 - 190
192-195	Power Supply	7D 64 07 00	2.5W (max), 1.5W (max, power down mode), 700mA (max, +3.3V)
196-211	Vendor SN	4C 54 30 30 30 38 32 32 20 20 20 20 20 20 20 20	Serial Number of transceiver (ASCII). For example “LT000822”.
212-219	Date code	xx xx xx xx xx xx 20 20	Year (2 bytes), Month (2 bytes), Day (2 bytes)
220	Diagnostic Monitoring Type	08	No BER Support, Average Power
221	Enhanced Options	60	Diagnostics(Optional Soft TX_DISABLE implemented, Optional Soft P_down implemented)
222	Aux Monitoring	70	Aux1 input: +3.3V Supply; Aux2 input: Auxiliary
223	CC_EXT	xx	Check sum for bytes 192-222
224-255		00	

**Note:** The “xx” byte should be filled in according to practical case. For more information, please refer to the related document of XFP\_SFF\_INF\_8077i Rev 4.5;

## Diagnostic Monitor Specifications

The monitoring specification of this product is described in Table 9.

**Table 9. Diagnostic Monitor Specifications**

	Parameter	Range	Accuracy	Calibration
96-97	Temperature(Tc)	-10 to +80°C	±3°C	Internal
	Temperature(Ti)	-40 to +90°C	±3°C	Internal
100-101	Bias Current	0 to 100mA	±10%	Internal
102-103	TX Power	-1 to +6dBm	±3dB	Internal
104-105	RX Power	-22 to -7dBm	±3dB	Internal
106-107	AUX1	3.0 to 3.7V	±3%	Internal
108-109	AUX2	NA	NA	NA

## Recommended Host Board Power Supply Filter Network

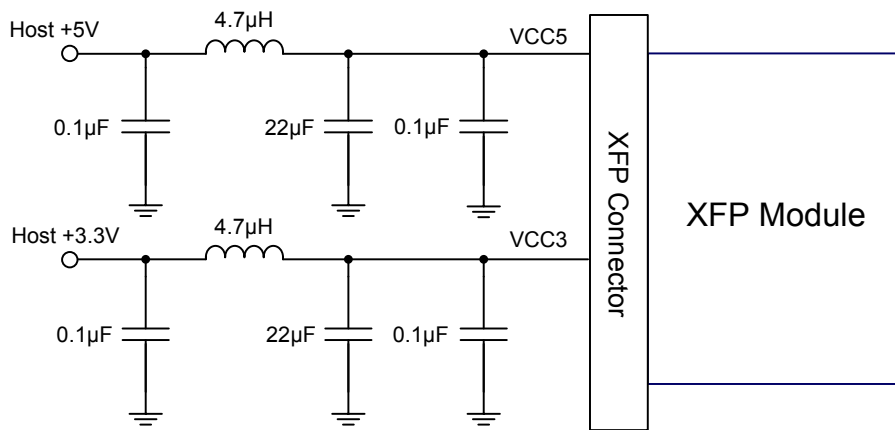

Figure 2. Recommended Host Board Power Supply Filter Network

## Recommended Application Interface Block Diagram

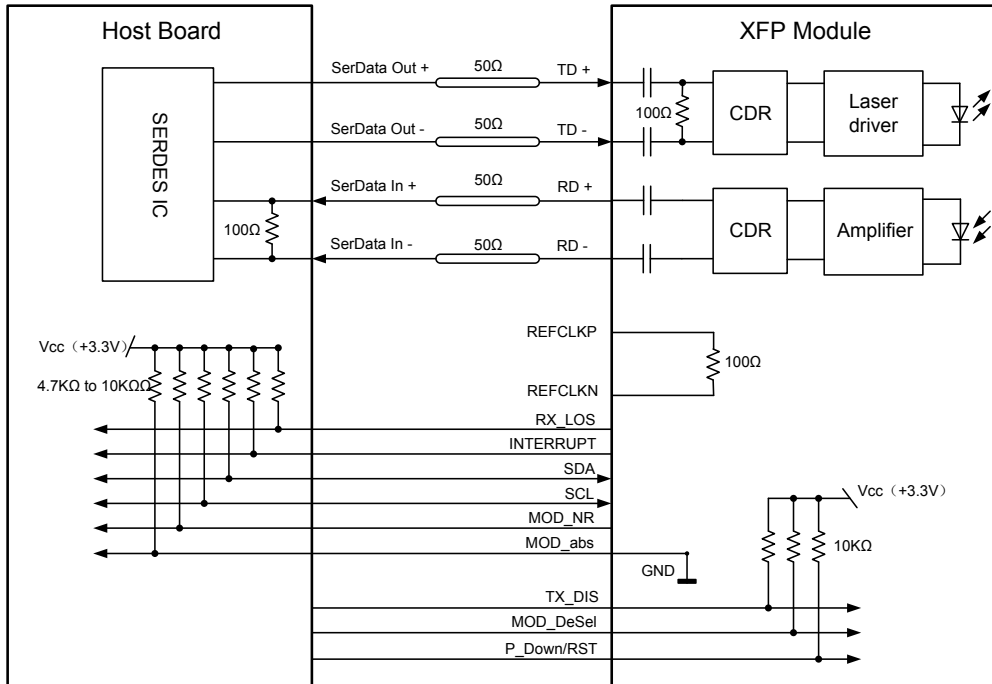

Figure 3. Recommended Application Interface Block Diagram



## Mechanical specifications

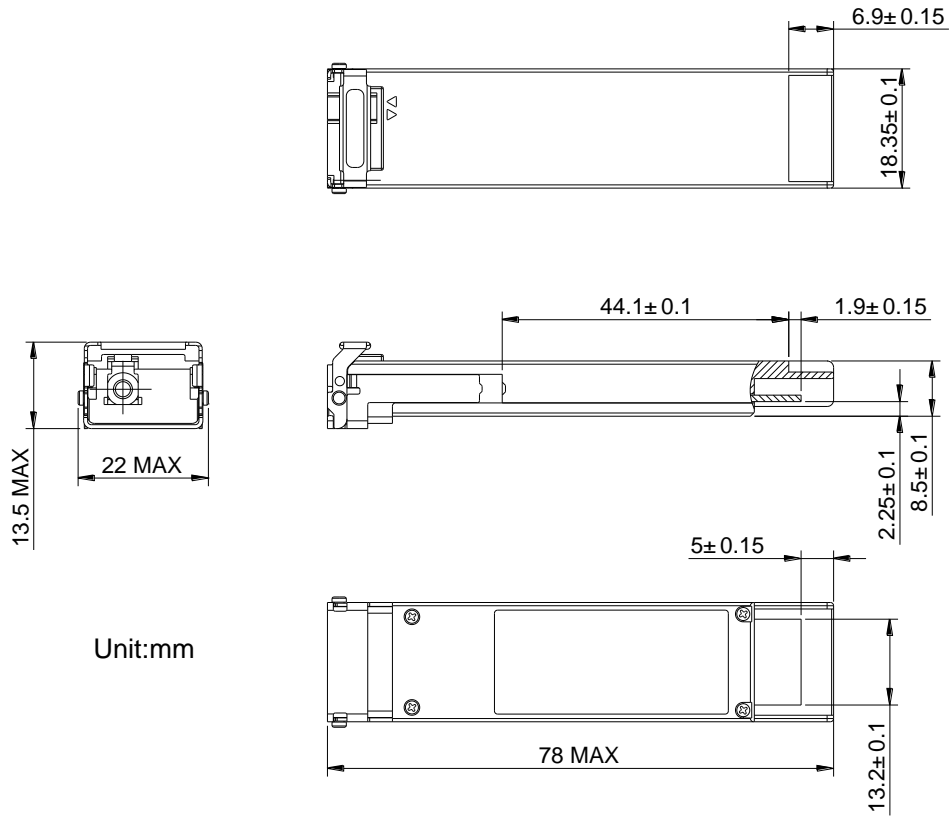

Figure 4. Outline Drawing

## **For More Information**

### **Linktel Technologies Co., Ltd**

sales@linkteltech.com

<http://www.linkteltech.com>

### **Linktel China**

No 20 University Science Park Road,  
East-Lake Hi-tech Development Zone, Wuhan, China  
Tel: +86 27-87929302

### **Linktel USA**

3391 Ingersoll Ct., San Jose, CA 95148  
Tel: +1-408-2613988