

Product Features

- Compliant with IEEE Std 802.3-2005, 1000BASE-BX-U
- Compliant with SFF-8074i and SFF-8472, revision 9.5
- Compliant with SFP MSA Specification
- Digital Diagnostic Monitoring available
- Uncooled 1310nm Fabry-Perot (FP) Laser
- Up to 1.25Gb/s bi-directional data links
- Up to 4km on 9/125µm SMF
- Simplex LC connector compliant
- Single +3.3V DC power supply
- Hot-pluggable SFP footprint
- Class 1 laser safety certified
- Operating temperature Options
 - (Commercial) -10°C to +70°C
 - (Extended) -10°C to +85°C
 - (Industrial) -40°C to +85°C
- RoHS6 Compliant



Applications

- 1000BASE-BX-U
- Fiber Channel Links: 1.0625Gb/s
- WDM Gigabit Ethernet Links
- Fast Ethernet
- Other Optical Links

Descriptions

LX2131C(E/I)DR SFP transceivers, according to Small Form Factor Pluggable Multi-Sourcing Agreement (MSA) SFF-8074i and SFF-8472, revision 9.5, are designed for single fiber bidirectional data communication up to 4km. They are compliant with IEEE Std 802.3ah-2005 1000BASE-BX-U.

LX2131C(E/I)DR SFP transceivers offer a wide range of design options, including Digital Diagnostic Monitoring (DDM) features and three temperature options (commercial, extended or industrial).

LX2131C(E/I)DR are compliant with RoHS.

Ordering Information

Table 1. Ordering Information

Part Number	Transmitter	Output Power	Receiver	Sensitivity	Reach	Temp	DDM	RoHS
LX2131CDR	1310nm FP	-9 ~ -3dBm	1550nm PIN	< -20dBm	4km	-10 ~ 70 °C	Available	Compliant
LX2131EDR	1310nm FP	-9 ~ -3dBm	1550nm PIN	< -20dBm	4km	-10 ~ 85 °C	Available	Compliant
LX2131IDR	1310nm FP	-9 ~ -3dBm	1550nm PIN	< -20dBm	4km	-40 ~ 85 °C	Available	Compliant

Pin Description

Table 2. Pin Description

Pin	Name	Function/Description	Engagement order (Insertion)	Notes
1	VeeT	Transmitter Ground	1	-
2	TX Fault	Transmitter Fault Indication	3	1
3	TX Disable	Transmitter Disable-Module disables on high or open	3	2
4	MOD-DEF2	Module Definition 2-Two wire serial ID interface	3	3
5	MOD-DEF1	Module Definition 1-Two wire serial ID interface	3	3
6	MOD-DEF0	Module Definition 0-Grounded in module	3	3
7	Rate Select	Not Connected	3	-
8	LOS	Loss of Signal	3	4
9	VeeR	Receiver Ground	1	-
10	VeeR	Receiver Ground	1	-
11	Veer	Receiver Ground	1	-
12	RD-	Inverse Received Data out	3	5
13	RD+	Received Data out	3	5
14	VeeR	Receiver Ground	1	-
15	VccR	Receiver Power - +3.3V±5%	2	6
16	VccT	Transmitter Power - +3.3 V±5%	2	6
17	VeeT	Transmitter Ground	1	-
18	TD+	Transmitter Data In	3	7
19	TD-	Inverse Transmitter Data In	3	7
20	VeeT	Transmitter Ground	1	-

Notes:

- TX Fault is open collector/drain output which should be pulled up externally with a 4.7KΩ-10KΩ resistor on the host board to supply $V_{ccT} + 0.3V$ or $V_{ccR} + 0.3V$. When high, this output indicates a laser fault of some kind. Low indicates normal operation. In the low state, the output will be pulled to <math>< 0.8V</math>.
- TX Disable input is used to shut down the laser output per the state table below. It is pulled up within the module with a 4.7KΩ-10KΩ resistor.
 - Low (0 – 0.8V): Transmitter on
 - Between (0.8V and 2V): Undefined
 - High (2.0 – V_{ccT}): Transmitter Disabled
 - Open : Transmitter Disabled
- Mod-Def 0, 1, 2. These are the module definition pins. They should be pulled up with a 4.7KΩ-10KΩ resistor on the host board to supply less than $V_{ccT} + 0.3V$ or $V_{ccR} + 0.3V$.
 - Mod-Def 0 is grounded by the module to indicate that the module is present.
 - Mod-Def 1 is clock line of two wire serial interface for optional serial ID.
 - Mod-Def 2 is data line of two wire serial interface for optional serial ID.
- LOS (Loss of signal) is an open collector/drain output which should be pulled up externally with a 4.7KΩ-10KΩ resistor on the host board to supply <math>< V_{ccT} + 0.3V</math> or $V_{ccR} + 0.3V$. When high, this output indicates the received optical power is below the worst case receiver sensitivity (as defined by the standard in use). Low indicates normal operation. In the low state, the output will be pulled to <math>< 0.8V</math>.

5. RD-/+ : These are the differential receiver outputs. They are AC coupled 100Ω differential lines which should be terminated with 100Ω differential at the user SERDES. The AC coupling is done inside the module and thus not required on the host board.
6. VccR and VccT are the receiver and transmitter power supplies. They are defined as 3.3V±5% at the SFP connector pin. The in-rush current will typically be no more than 30mA above steady state supply current after 500ns.
7. TD-/+ : These are the differential transmitter inputs. They are AC coupled differential lines with 100Ω differential termination inside the module. The AC coupling is done inside the module and is thus not required on host board.

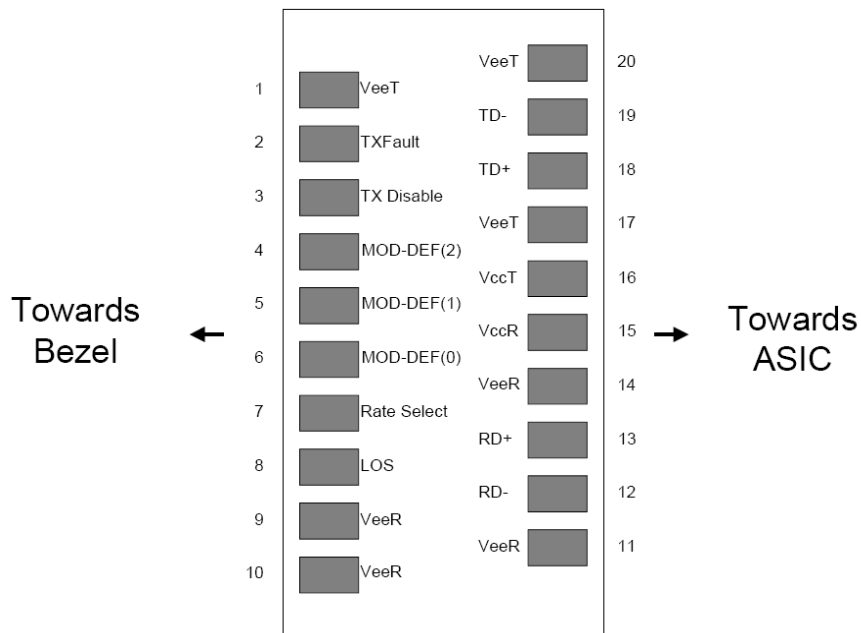

Figure 1. Diagram of Host Board Connector Block Pin Numbers and Names

Absolute Maximum Ratings

Stresses in excess of the absolute maximum ratings can cause permanent damage to the device. These are absolute stress ratings only. Functional operation of the device is not implied at these or any other conditions in excess of those given in the operational sections of the data sheet. Exposure to absolute maximum ratings for extended periods can adversely affect device reliability.

Table 3. Absolute Maximum Ratings

Parameter	Symbol	Minimum	Maximum	Unit
Storage Temperature	T _S	-40	85	°C
Relative Humidity	RH	5	95	%
Supply Voltage	V _{CC}	-0.5	4.0	V

Recommended Operating Conditions

Table 4. Recommended Operating Conditions

Parameter	Symbol	Min	Typ	Max	Unit	
Operating Case Temperature	LX2131CDR	T _C	-10	25	70	°C
	LX2131EDR	T _C	-10	25	85	°C
	LX2131IDR	T _C	-40	25	85	°C
Supply Voltage	V _{CC}	3.135	3.3	3.465	V	
Data Rate	-	0.1	-	1.25	Gb/s	

Transceiver Electrical Characteristics

Table 5. Transceiver Electrical Characteristics

Parameter	Symbol	Minimum	Typical	Maximum	Unit	Notes
Module Supply Current	I _{CC}	-	-	220	mA	-
Power dissipation	P _D	-	-	800	mW	-
Transmitter Differential Input Voltage (TD +/-)	-	300	-	2200	mV _{P-P}	1
Receiver Differential Output Voltage (RD +/-)	-	600	-	1200	mV _{P-P}	2
Low speed output: Transmitter Fault (TX_FAULT) / Loss of Signal (LOS)	VOH	2.0	-	V _{CC}	V	3
	VOL	0	-	0.8	V	-
Low speed input: Transmitter Disable (TX_DISABLE), MOD_DEF 1, MOD_DEF 2	VIH	2.0	-	V _{CC}	V	4
	VIL	0	-	0.8	V	-

Notes:

- Internally AC coupled and terminated to 100Ω differential load.
- Internally AC coupled, but requires a 100Ω differential termination or internal to Serializer/Deserializer.
- Pulled up externally with a 4.7KΩ-10KΩ resistor on the host board to V_{CCT,R}.
- Mod_Def1 and Mod_Def2 must be pulled up externally with a 4.7KΩ-10KΩ resistor on the host board to V_{CCT,R}.

Transmitter Optical Characteristics

Table 6. Transmitter Optical Characteristics

Parameter	Symbol	Minimum	Typical	Maximum	Unit	Notes
Launch Optical Power	P _o	-9	-6	-3	dBm	-
Center Wavelength Range	λ _c	1260	1310	1360	nm	-
Extinction Ratio	EX	9	-	-	dB	-
Spectral Width(RMS)	Δλ	-	-	4	nm	-
Optical Rise/Fall Time	T _{rise} /T _{fall}	-	-	260	ps	-
Pout @TX-Disable Asserted	P _{off}	-	-	-45	dBm	-
Eye Diagram	IEEE Std 802.3-2005 1000BASE-BX10-U compatible					

Receiver Optical Characteristics

Table 7. Receiver Optical Characteristics

Parameter	Symbol	Minimum	Typical	Maximum	Unit	Notes
Wavelength Range	-	1470	1550	1600	nm	-
Receiver Sensitivity	S	-	-	-20	dBm	1
Receiver Overload	P _{OL}	-3	-	-	dBm	1
Optical Return Loss	ORL	12	-	-	dB	-
LOS De-Assert	LOS _D	-	-	-21	dBm	-
LOS Assert	LOS _A	-35	-	-	dBm	-
LOS Hysteresis	-	0.5	3	5	dB	-

Notes:

1. Measured with PRBS 2⁷-1 test pattern, 1.25Gb/s, EX=9dB, BER<10⁻¹².

Timing characteristic

Table 8. Receiver Optical Characteristics

Parameter	Symbol	Minimum	Typical	Maximum	Unit	Notes
Tx_disable assert time	T _{off}	-	-	10	us	-
Tx_disable negate time	T _{on}	-	-	1	ms	-
Time to initialize, include reset of TX_FAULT	T _{init}	-	-	300	ms	-
TX_FAULT from fault to assertion	T _{fault}	-	-	100	us	-
Tx_disable time to start reset	T _{reset}	10	-	-	us	-
Receiver LOS Assert Time(on to off)	T _{D,RX_LOS}	-	-	80	us	-
Receiver LOS Assert Time(off to on)	T _{A,RX_LOS}	-	-	80	us	-
Serial I2C Clock Rate	I2C_Clock	-	-	100	kHz	-

Digital Diagnostic Memory Map

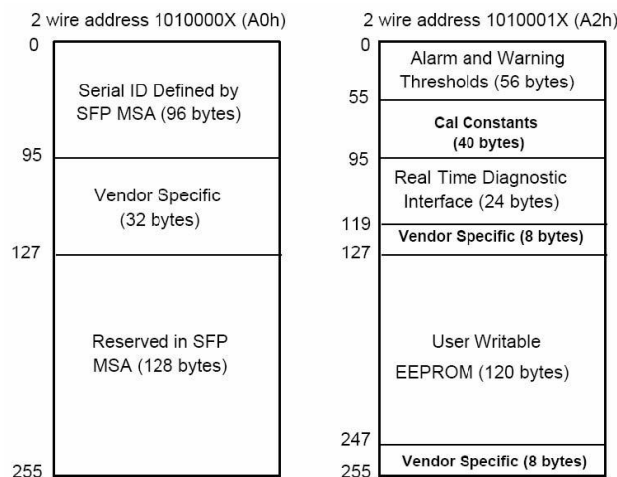

Figure 2. Digital Diagnostic Memory Map Specific Data Field Descriptions

EEPROM Serial ID Memory Contents

The SFP MSA defines a 256-byte memory map in EEPROM describing the transceiver’s capabilities, standard interfaces, manufacturer, and other information, which is accessible over a 2 wire serial interface at the 8-bit

address 1010000X (A0h), and the clock frequency up to 100KHz. The memory contents are shown in Table 9.

Table 9. Serial ID Memory Contents

Data Address	Name of Field	Contents(Hex)	Description
0	Identifier	03	SFP
1	Ext. Identifier	04	SFP function is defined by serial ID
2	Connector	07	LC
3-10	Transceiver	00 00 00 40 00 00 00 00	1000BASE-BX-U
11	Encoding	03	NRZ
12	BR, Nominal	0D	1.25Gb/s
13	Reserved	00	-
14	Length (9µm) km	04	4km
15	Length (9µm) 100m	28	4000m
16	Length (50µm) 10m	00	-
17	Length(62.5µm)10m	00	-
18	Length (Copper)	00	-
19	Reserved	00	-
20-35	Vendor name	4C 49 4E 4B 54 45 4C 20 20 20 20 2020 20 20 20	“LINKTEL”(ASCII)
36	Reserved	00	
37-39	Vendor OUI	00 00 00	
40-55	Vendor PN	4C 58 32 31 33 31 xx 44 52 20 20 20 20 20 20 20	“LX2131xDR ” (ASCII)
56-59	Vendor rev	31 2E 30 20	Rev 1.0 (ASCII)
60-61	Wavelength	05 1E	1310nm
62	Reserved	00	
63	CC BASE	xx	Check sum of bytes 0 - 62
64-65	Options	00 1A	LOS, TX_FAULT and TX_DISABLE
66	BR, max	00	
67	BR, min	00	
68-83	Vendor SN	xx xx xx xx xx xx xx xx xx xx xx xx xx xx xx xx	ASCII
84-91	Vendor date code	xx xx xx xx xx xx 20 20	Year (2 bytes), Month (2 bytes), Day (2 bytes)
92	Diagnostic type	68	Diagnostics (Internally Cal)
93	Enhanced option	B0	Diagnostics(Optional Alarm/warning flags, Soft TX_FAULT and Soft TX_LOS monitoring)
94	SFF-8472	02	Diagnostics(SFF-8472 Rev 9.5)
95	CC_EXT	xx	Check sum for bytes 64-94
96-255		00	

Note: The “xx” byte should be filled in according to practical case. For more information, please refer to the related document

of SFF-8472 Rev 9.5.

Diagnostic Monitor Specifications

The digital diagnostic monitoring interface also defines another 256-byte memory map in EEPROM, which makes use of the 8 bit address 1010001X (A2h). Please see Figure 2. For detail EEPROM information, please refer to the related document of SFF-8472 Rev 9.5. The monitoring specification of this product is described in Table 10.

Table 10. Diagnostic Monitor Specifications

Parameter	Range	Accuracy	Calibration
Temperature	LX2131CDR	-15 to +80°C	±3°C
	LX2131EDR	-15 to +95°C	±3°C
	LX2131IDR	-45 to +95°C	±3°C
Voltage	3.0 to 3.6V	±3%	Internal
Bias Current	0 to 70mA	±10%	Internal
TX Power	-10 to -2dBm	±3dB	Internal
RX Power	-21 to -2dBm	±3dB	Internal

Required Host Board Components

The MSA power supply noise rejection filter is required on the host PCB to meet data sheet performance. The MSA filter incorporates an inductor which should be rated 400mA DC and 1Ω serial resistance or better. It should not be replaced with a ferrite. The required filter is illustrated in Figure 3. The MSA also specifies that 4.7KΩ to 10KΩ pull-up resistors for TX_FAULT, LOS, and MOD_DEF0,1,2 are required on the host PCB. Figure is the suggested transceiver/host interface.

Figure 3 shows the recommended host board power supply circuit.

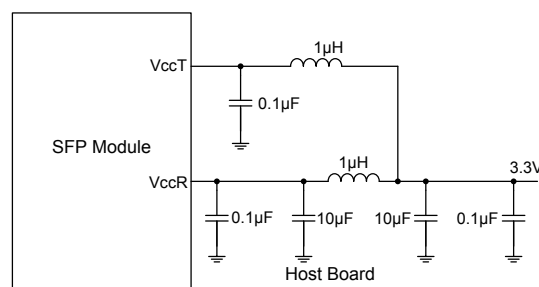

Figure 3. Recommended Host Board Power Supply Circuit

Recommended Application Interface Circuit

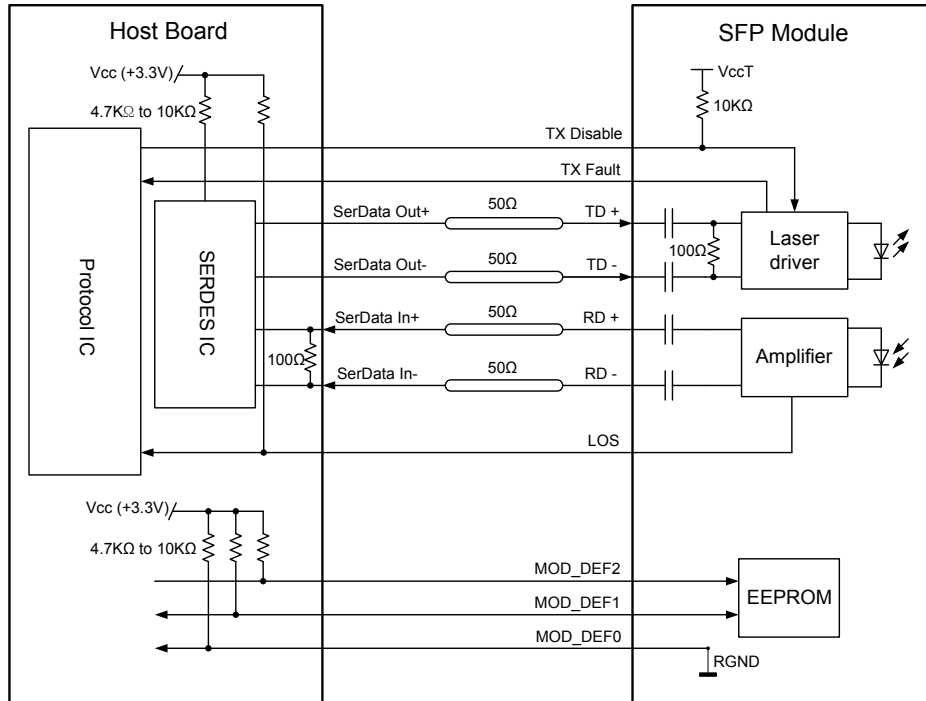

Figure 4. Recommended Application Interface Circuit

Mechanical specifications

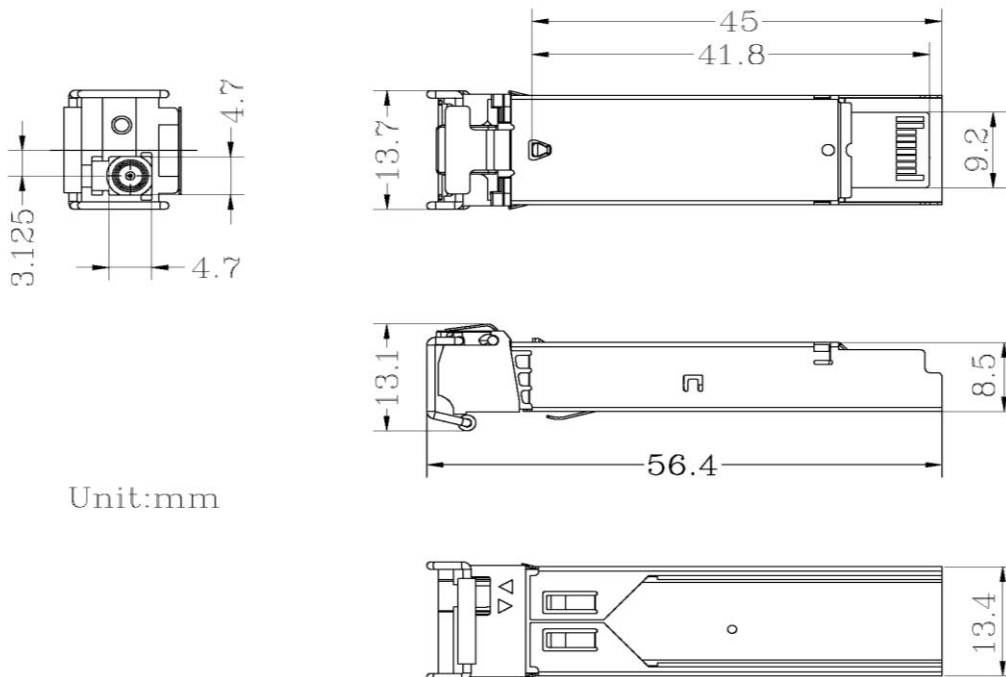

Figure 5. Outline Drawing

PCB layout recommendation

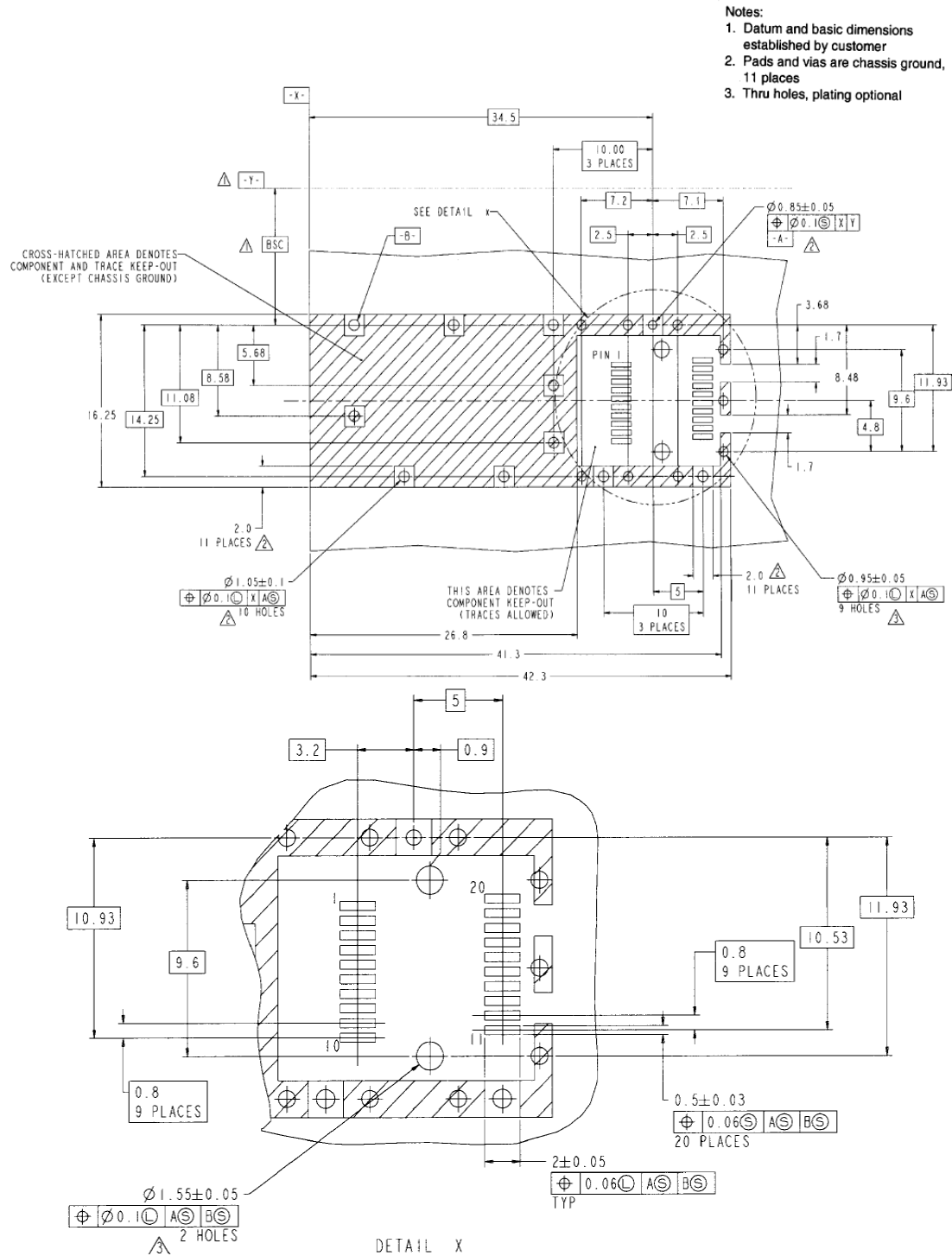

Figure 6. PCB layout recommendation



LX2131xDR
100Mb/s to 1.25Gb/s Bi-directional SFP Transceiver
4km 1000BASE-BX-U

For More Information

Linktel Technologies Co., Ltd

sales@linkteltech.com

<http://www.linkteltech.com>

Linktel China

No.20 University Science Park Road,

East Lake Hi-tech Development Zone, Wuhan, 430223, China

Tel: +86 27-87929302

Linktel USA

3391 Ingersoll Ct., San Jose, CA 95148

Tel: +1-408-2613988